



Since 1998
The way of lifting, the way of success.
源于热爱，成于坚持。



Yingkou Qishida Machinery Equipment Co.,Ltd

Tel:+86-0417-4896663

E-mail: anyuchen@qishida.com

Website: www.worldqishida.com

LIFT PRODUCTS
举升机系列

2023

version:2023.10



A RELIABLE PARTNER

One Stop service

Top rated auto lift supplier

20 Years OEM manufacturing experience

200,000+ Products all over the world



Yingkou Qishida Machinery Equipment Co.,Ltd is a top-rated Chinese manufacturer with more than 20 year's experience researching, marketing and manufacturing of car repair lifts, parking lifts and motorcycle lifts. Our company is headquartered in Yingkou city, Liaoning province in the north of China. The company was found in 1998 and the production factory is more than 30,000 square meter.

As one of the greatest industry brands in China, we have wide range of OEM customers all over the world since 2002. In addition, we have overseas distributor of Qishida brand products as well. For the technical support, we cooperate with Italian company since 2008 and many products are international-patented.

Qishida is dedicated to provide reliable automotive repair products to the customers all the time. We are looking forward to expanding more international business with you in the future!

营口骑士达机械设备有限公司坐落于东北工业基地 - 辽宁省营口市自由贸易试验区, 厂区占地面积 3 万多平方米, 是全国领先的设计, 研发, 销售一体的专业汽保设备生产企业。公司拥有国内外领先的生产技术, 精良设备及完善的品控体系, 历经 20 多年的发展已发展成为中国汽保行业的高端制造企业中的一员。

公司自 1998 年成立至今, 根据国内外市场的不同需求先后设计和研发了柱式举升机系列、停车场举升机系列、摩托车举升系列及其他汽车保修类产品, 出口全世界 150 多个国家及地区; 骑士达品牌举升机经过多年与意大利和德国技术公司的合作, 现已成为中国汽保设备行业内的优质品牌生产商!

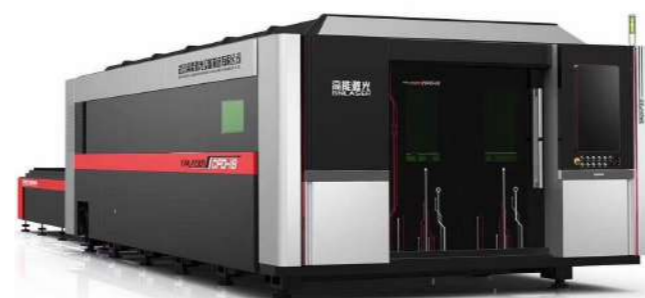

目录

CONTENTS

Entry Level-2 Post Lift 入门系列双柱举升机

- 01 QSD3500S
- 02 QSD3800S

Professional Level-2 Post Lift 专业系列双柱举升机

- 03 QSD4.0-DB2
- 04 QSD4.0-DB2L

Expert Level-2 Post Lift 专家系列双柱举升机

- 05 QSD4000A
- 06 QSD3800

Heavy-duty Level-2 Post Lift 重吨位系列双柱举升机

- 07 QSD5000
- 08 QSD5000B

Scissor Lift 剪式举升机

- 09-10 QSD X3.0M / QSD X3.0E
- 11-12 JS3000C
- 13-14 DC3000
- 15-16 CB3000

Motorcycle Lift 摩托车举升机

- 17-18 QYK-ML600

2-Post Parking Lift 双柱停车场

- 19-20 QYK-ET30

QSD3500S QSD3800S

Entry Level 2-Post Lifts Double-side Manual Safety Lock Release 入门系列 - 双边手动解锁双柱举升机

QSD3500S



Dual Manual
Lock Release
双边手动解锁

QSD3800S



Dual Manual
Lock Release
双边手动解锁



Split-column for export
edition of QSD3800S
分段式立柱设计
(出口款)

OPTIONAL ACCESSORIES 可选配件



Height adapters for suvs &
trucks
适用于各种车型的增高套



Column anti-dust
cover
立柱防尘遮布

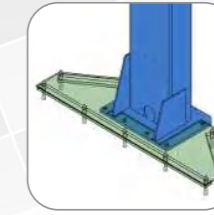

Floor reinforcement
加强底座降低打孔
深度

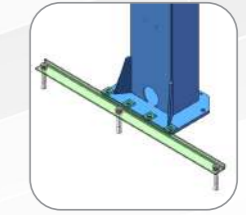

Ground support frames
底板固定横担

OVERALL DIMENSION 尺寸参数

QSD3500S

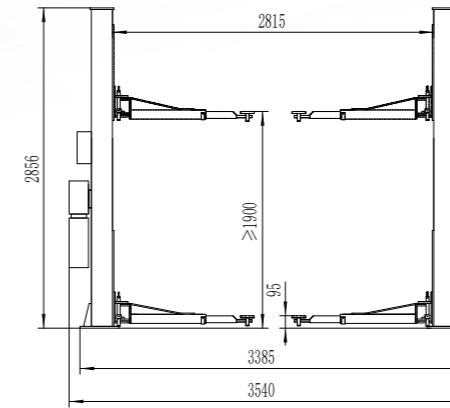

QSD3800S

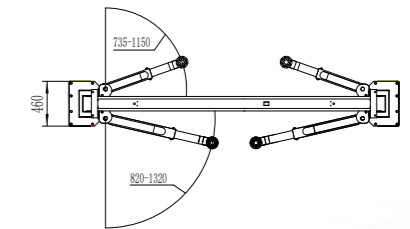
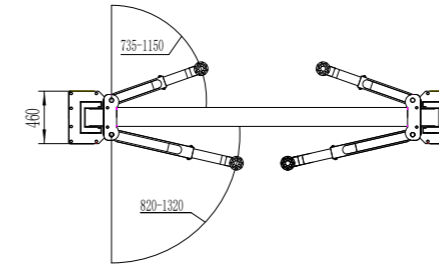
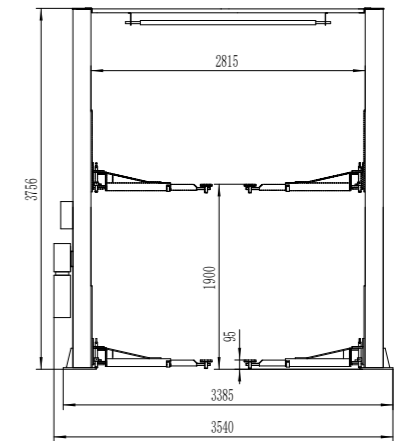

FEATURES 产品特点



Automatic arm-
locking system
托臂锁自动上锁设计



Chain protector
链条防脱装置

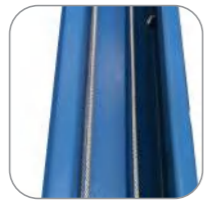

Synchronization
cable
钢丝绳同步



Car door protection
车门防撞垫



Safety valves against
hose breaking
安全阀确保使用安全

STANDARD 标准配置



1-stage adjustable
lifting pad
单螺旋举升托盘



Steel motor
钢板电机

OPTIONAL FEATURES 此产品可选升级方案



2-stage adjustable
lifting pad
双螺旋举升托盘



Aluminum motor
铝电机泵站



Foot protection
防压脚装置



3-stage front arms
(690mm-1290mm)
3 段式前托臂
(690mm-1290mm)

TECHNICAL DATA 技术参数

Model	型号	QSD3500S	QSD3800S
Capacity	举升重量	4000kg	4000kg
Lifting height	举升高度	1900mm	1900mm
Min. Height	最低高度	95mm	95mm
Overall height	总高度	2856mm	3756mm
Overall width	总宽度	3385mm	3385mm
Front arm(2-stage)	前托臂 (2 段式)	735-1150mm	735-1150mm
Rear arm(2-stage)	后托臂 (2 段式)	820-1320mm	820-1320mm
Lifting time	上升时间	45-50s	45-50s
Power of motor	电机功率	2.2kW	2.2kW

QSD4.0-DB2 QSD4.0-DB2L

Professional Level 2-Post Lifts Single-side Manual Safety Lock Release 专业系列 - 单边手动解锁双柱举升机

QSD4.0-DB2



QSD4.0-DB2L



OPTIONAL ACCESSORIES 可选配件

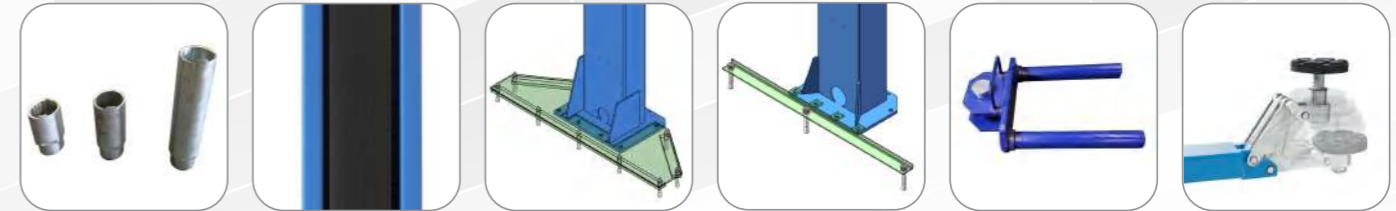

Height adapters for suvs & trucks
适用于各种车型的增高套

Column anti-dust cover
立柱防尘遮布

Floor reinforcement
加强底座降低打孔深度

Ground support frames
底板固定横担

Special adapter for battery car
电动车托胎器

Fast adjustable pad
快速托盘

OVERALL DIMENSION 尺寸参数

QSD4.0-DB2

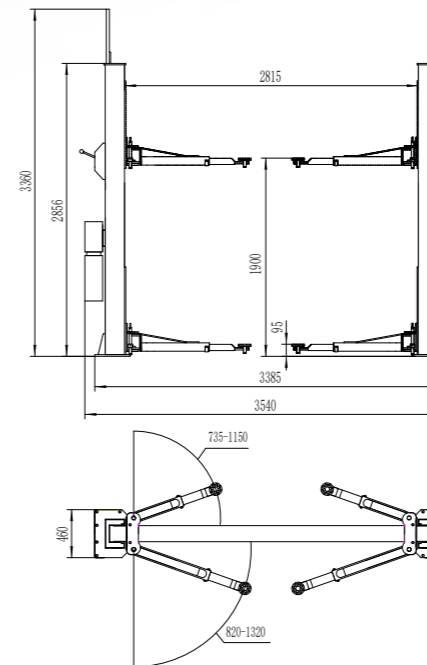

QSD4.0-DB2L

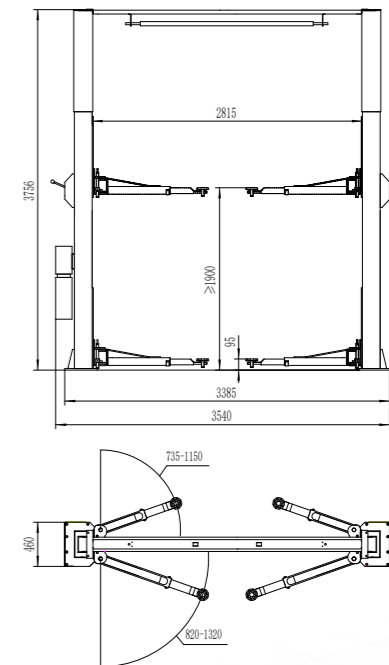

FEATURES 产品特点



Automatic arm-locking system
托臂锁自动上锁设计



Chain protector
链条防脱装置

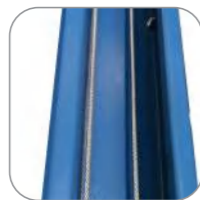

Synchronization cable
钢丝绳同步



Car door protection
车门防撞垫



Safety valves against hose breaking
安全阀确保使用安全

STANDARD 标准配置



1-stage adjustable lifting pad
单螺旋举升托盘



Steel motor
钢板电机

OPTIONAL FEATURES 此产品可选升级方案



2-stage adjustable lifting pad
双螺旋举升托盘



Aluminum motor
铝电机泵站



24v safety control box
24v 安全操作电控箱



Foot protection
防压脚设计



3-stage front arms
(690mm-1290mm)
3 段式前托臂
(690mm-1290mm)

TECHNICAL DATA 技术参数

Model	型号	QSD4.0-DB2	QSD4.0-DB2L
Capacity	举升重量	4000kg	4000kg
Lifting height	举升高度	1900mm	1900mm
Min. Height	最低高度	95mm	95mm
Overall height	总高度	2856mm	3756mm
Overall width	总宽度	3385mm	3385mm
Front arm(2-stage)	前托臂 (2 段式)	735-1150mm	735-1150mm
Rear arm(2-stage)	后托臂 (2 段式)	820-1320mm	820-1320mm
Lifting time	上升时间	45-50s	45-50s
Power of motor	电机功率	2.2kW	2.2kW

QSD4000A QSD3800

Expert Level 2-Post Lifts
Electric Safety Lock Release
专家系列 - 电解锁双柱举升机

QSD4000A



Electric Lock Release
电动解锁



Electromagnetic Lowering
电磁下降

QSD3800



Electric Lock Release
电动解锁



Electromagnetic Lowering
电磁下降



Optional 3-stage front arms
(690mm-1290mm)
可选配 3 段式前托臂
(690mm-1290mm)



OPTIONAL ACCESSORIES 可选配件



Height adapters for suvs & trucks
适用于各种车型的增高套



Anti-dust column cap (QSD4000A)
立柱防尘装饰帽 (QSD4000A)

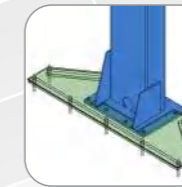

Floor reinforcement
加强底座降低打孔深度

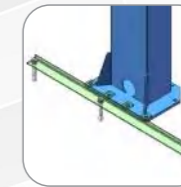

Ground support frames
底板固定横担



Special adapter for battery car
电动车托胎器



Fast adjustable pad
快速托盘

OVERALL DIMENSION 尺寸参数

QSD4000A

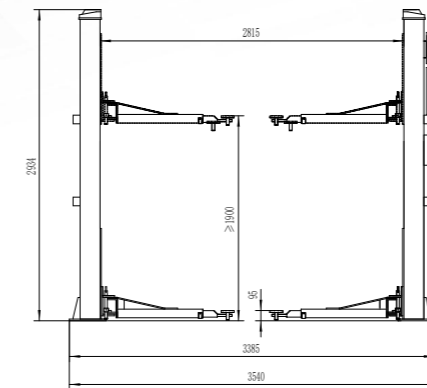

QSD3800

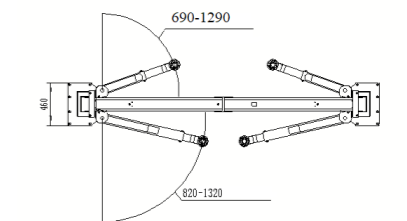
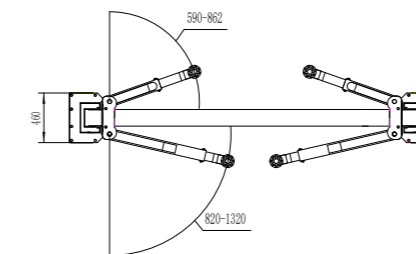
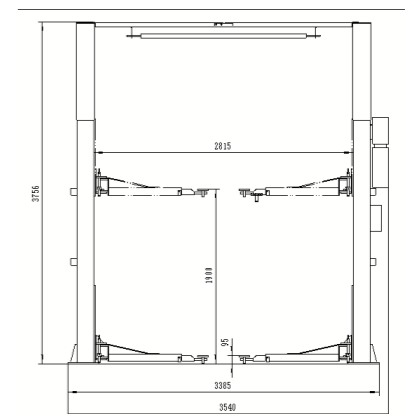

FEATURES 产品特点



Automatic arm-locking system
托臂锁自动上锁设计



Chain protector
链条防脱装置

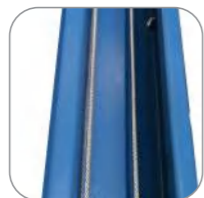

Synchronization cable
钢丝绳同步



Car door protection
车门防撞垫



24v safety control box
24v 安全操作电控箱



Safety valves against hose breaking
安全阀确保使用安全

STANDARD 标准配置



1-stage adjustable lifting pad
单螺旋举升托盘



Aluminum motor lifting pad
标配铝电机泵站



Column anti-dust cover
立柱防尘遮布

OPTIONAL FEATURES 此产品可选升级方案



2-stage adjustable lifting pad
双螺旋举升托盘

TECHNICAL DATA 技术参数

Model	型号	QSD4000A	QSD3800
Capacity	举升重量	4000kg	4000kg
Lifting height	举升高度	1900mm	1900mm
Min. Height	最低高度	95mm	95mm
Overall height	总高度	2856mm	3756mm/4000mm/4500mm
Overall width	总宽度	3385mm	3385mm
Front arm	前托臂	590-862mm	690-1290mm
Rear arm	后托臂	820-1320mm	820-1320mm
Lifting time	上升时间	45-50s	45-50s
Power of motor	电机功率	2.2kW	2.2kW

QSD5000 QSD5000B

Heavy-duty Level 2-Post Lifts 5.0 Ton Capacity Electric Safety Lock Release 重吨位系列 - 电解锁双柱举升机

QSD5000



QSD5000B



OPTIONAL ACCESSORIES 可选配件



Height adapters for vans & trucks (100/150/200mm)
100/150/200mm 增高套

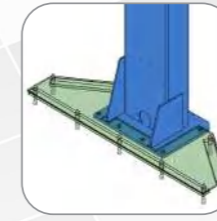

Floor reinforcement
加强底座降低打孔深度



Special adapter for battery car
电动车托胎器



Fast adjustable pad
快速托盘

OVERALL DIMENSION 尺寸参数

QSD5000

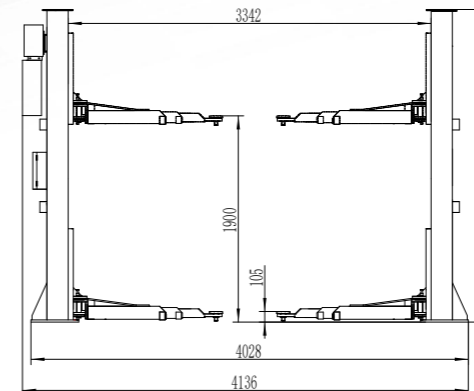

QSD5000B

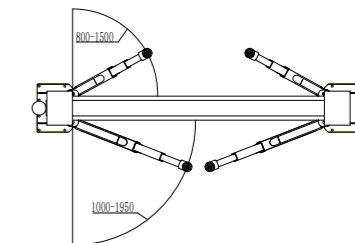
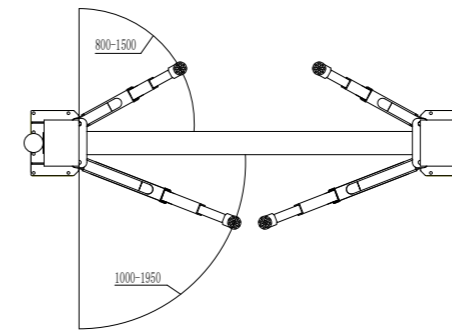
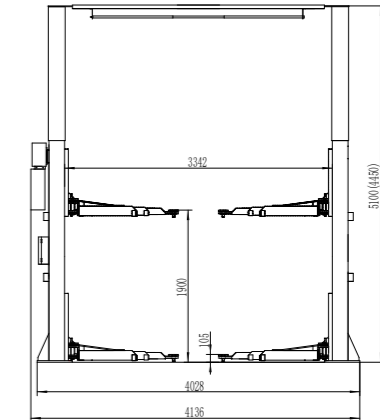

FEATURES 产品特点

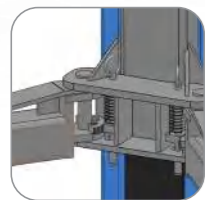

Automatic arm-locking system
托臂锁自动上锁设计

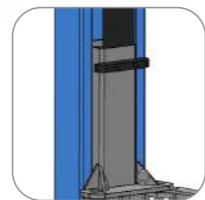

Car door protection
车门防撞垫



Column anti-dust cover
立柱防尘遮布



24v safety control box
24v 安全操作电控箱



Safety valves against hose breaking
安全阀确保使用安全

STANDARD 标准配置



2-stage adjustable lifting pad
双螺旋举升托盘



Aluminum motor
标配铝电机泵站



85mm height adapters (4 pcs)
4 个 85mm 增高套

TECHNICAL DATA 技术参数

Model	型号	QSD5000	QSD5000B
Capacity	举升重量	5000kg	5000kg
Lifting height	举升高度	1900mm	1900mm
Min. Height	最低高度	105mm	105mm
Overall height	总高度	2880mm	4450mm/5100mm
Overall width	总宽度	4028mm	4028mm
Front arm(3-stage)	前托臂 (3 段式)	800-1500mm	800-1500mm
Rear arm(3-stage)	后托臂 (3 段式)	1000-1950mm	1000-1950mm
Lifting time	上升时间	45-50s	45-50s
Power of motor	电机功率	2.2kW	2.2kW

QSD X3.0M QSD X3.0E



Mobile Scissor Lift With Manual/Electrical Lock Release
移动式剪式升降机 (手动解锁 / 电动解锁)

OVERALL DIMENSION 尺寸参数

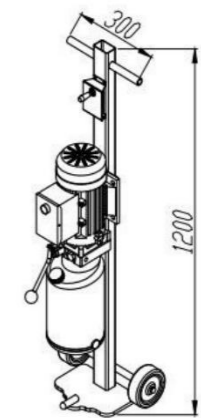
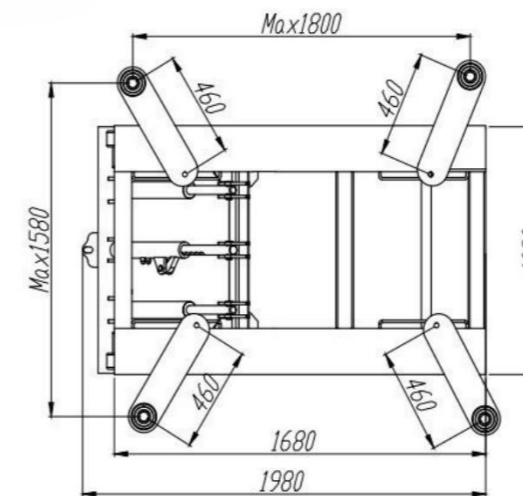
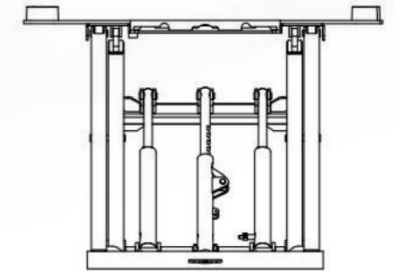
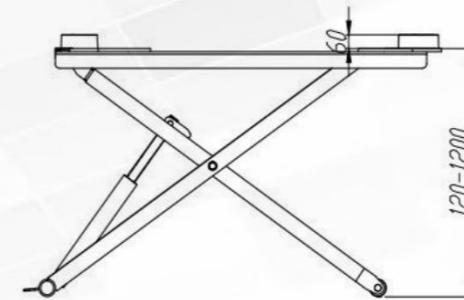

FEATURES 产品特点

- ✓ 3000KG (6,600lbs) lifting capacity
- ✓ Perfect lift for painting jobs and bodywork, brakes and tire service
- ✓ Manual safety lock release
- ✓ Electrical safety lock release version (**QSD X3.0E**) is also available
- ✓ Automatic arm locking system, which makes sure the lifting arms can not move when the car is placed on the lift
- ✓ Portable motor cart serves as tow dolly, making it portable and able to operate on concrete indoors or outdoors
- ✓ Dual cylinder structure, ensure stable raising and lowering
- ✓ Multiple locking positions accommodates higher profile vehicles and provides maximum headroom to work underneath vehicles
- ✓ Powder coated finish provides long-lasting durable use
- ✓ Each lift passes the 115% rated capacity (3,450kg) dynamic load test and 150% rated capacity (4,500kg) static load test, safe and reliable.

型号	Model	QSD X3.0M/QSD X3.0E
举升重量	Capacity	3000kg
举升高度	Lifting height	1200mm
最低高度	Min.height	120mm
上升时间	Lifting time	30-35s
电机功率	Motor power	2.2kW

JS3000C

Moblie Mid-rise Scissor Lift With Electric Safety Lock Release 移动式中位小剪举升机



OPTIONAL ACCESSORIES 可选配件



Lifting pads
60mm/80mm/100mm
举升胶垫
60mm/80mm/100mm

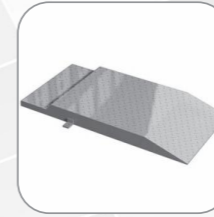

Additional drive-on ramps
加长上车跑板



SUV adapter kit
SUV 加高支架

OVERALL DIMENSION 尺寸参数

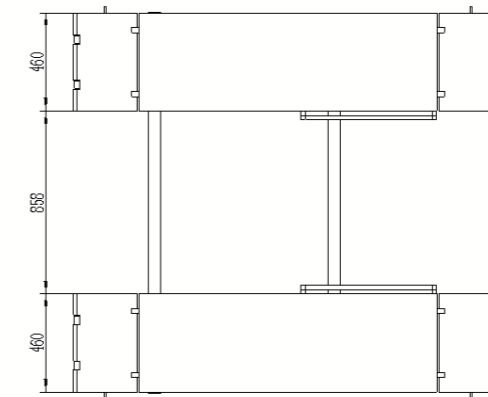
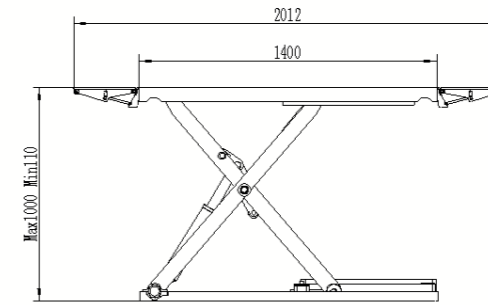

FEATURES 产品特点

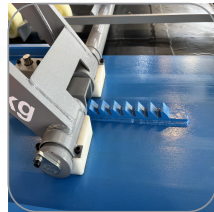

Automatic lock & release
全自动解锁 & 上锁



Stable launch & land design
加强助力器设计

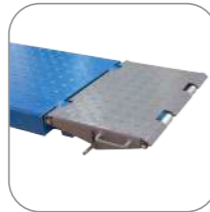

Extendible ramps
加长延伸板

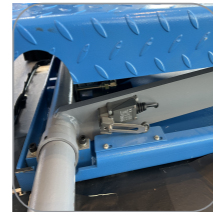

CE-Stop (foot protection)
下限位开关 (防压脚设计)



Mobile design
可移动小剪设计

STANDARD 标准配置



35mm lifting pads (4 pcs)
35mm 举升胶垫 (4个)

OPTIONAL FEATURES 此产品可选升级方案



Mobile kit
移动组件

TECHNICAL DATA 技术参数

Model	型号	JS3000C
Capacity	举升重量	3000kg
Lifting height	举升高度	1000mm
Min. Height	最低高度	110mm
Platform length	平台长度	1400-2012mm
Overall width	总宽度	1778mm
Lifting time	上升时间	30-35s
Power of motor	电机功率	2.2kW

DC3000



In-floor full rise scissor lift 藏地式剪式举升机

Pneumatic Lock Release
气动解锁

Electromagnetic Lowering
电磁下降



OPTIONAL ACCESSORIES 可选配件



SUV adapter kit
SUV 加高支架

OVERALL DIMENSION 尺寸参数

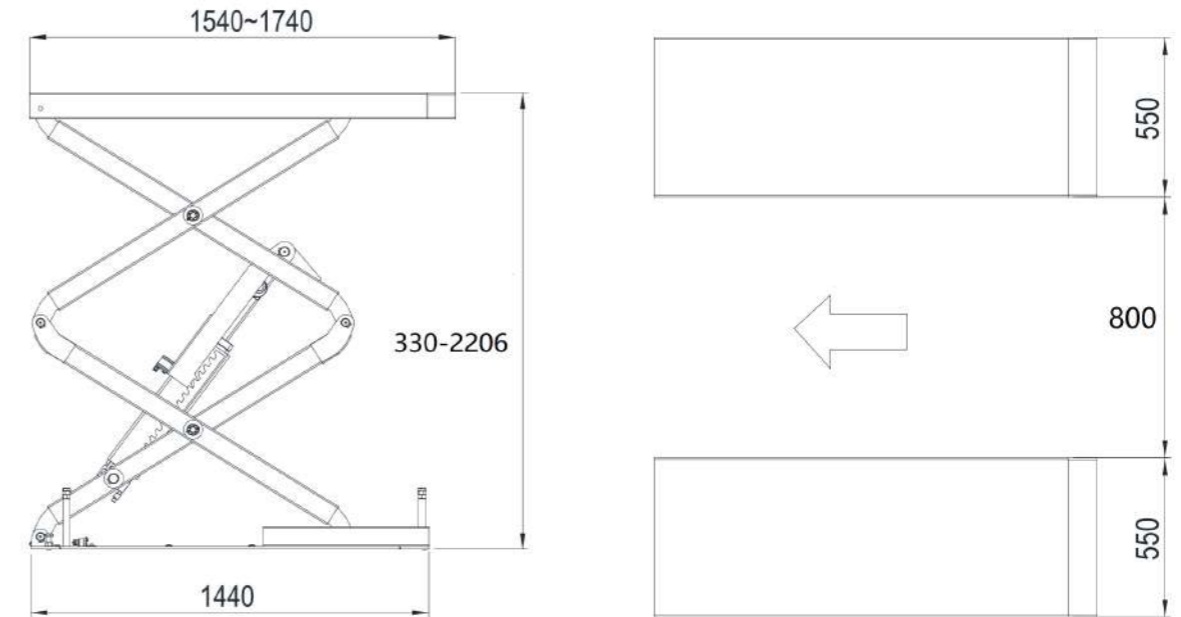

FEATURES 产品特点



Automatic lock & release
全自动解锁 & 上锁



Height limit switch
上限位开关

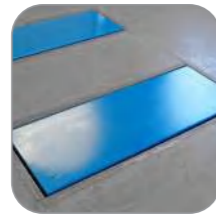

In-floor design
地藏式安装



Automatic air bleeding by button
一键调平功能



Sliding extension on platform
单侧可抽拉式平台

STANDARD 标准配置



35mm lifting pads (4 pcs)
35mm 举升胶垫 (4个)

TECHNICAL DATA 技术参数

Model	型号	DC3000
Capacity	举升重量	3000kg
Lifting height	举升高度	2206mm
Min. Height	最低高度	330mm
Platform length	平台长度	1540mm-1740mm
Lifting time	上升时间	45-50s
Power of motor	电机功率	2.2kW

CB3000



On-floor low profile double scissor lift 超薄式小剪举升机

OPTIONAL ACCESSORIES 可选配件



SUV adapter kit
SUV 加高支架



Double master / slave system,
therefore no compressed air and
no safety rack necessary!
双油路设计完美保障液压安全,
无需气源和安全锁!

OVERALL DIMENSION 尺寸参数

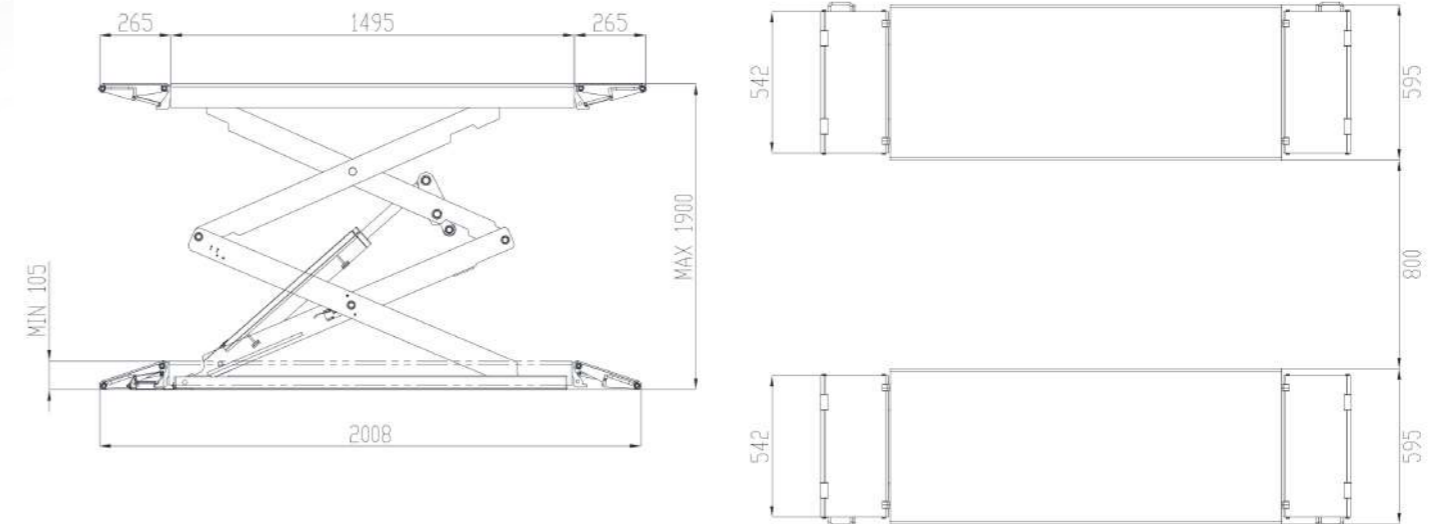

FEATURES 产品特点



Ultra-flat design
超薄省空间设计



Automatic air bleeding by
button
一键调平功能



Dual double
cylinders design
4 油缸同步系统



Electronic synchronization
through photo sensor and
reflector
电子装置防止车辆侧翻

STANDARD 标准配置

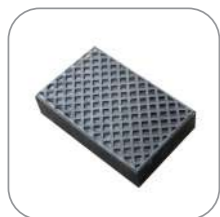

Rubber pads (4 pcs)
举升胶垫 4 个

TECHNICAL DATA 技术参数

Model	型号	CB3000
Capacity	举升重量	3000kg
Lifting height	举升高度	1900mm
Min. Height	最低高度	105mm
Platform length	平台长度	1495mm-2025mm
Overall width	总宽度	1990mm
Lifting time	上升时间	45-50s
Power of motor	电机功率	2.2kW

QYK-ML600

Electro-hydraulic motorcycle lift
电动液压摩托车举升机

QYK-ML600 



QYK-ML600 + ATV extensions kit



OPTIONAL ACCESSORIES 可选配件



ATV extensions kit
加宽延伸板用于四轮摩托



500KG Mini Lifter
500KG 千斤顶

OVERALL DIMENSION 尺寸参数

QYK-ML600

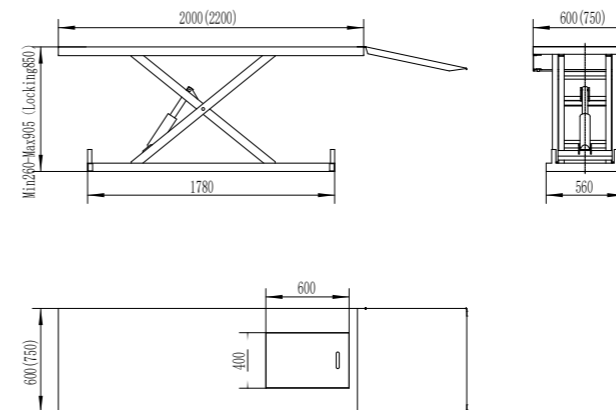

QYK-ML600 + ATV extensions kit

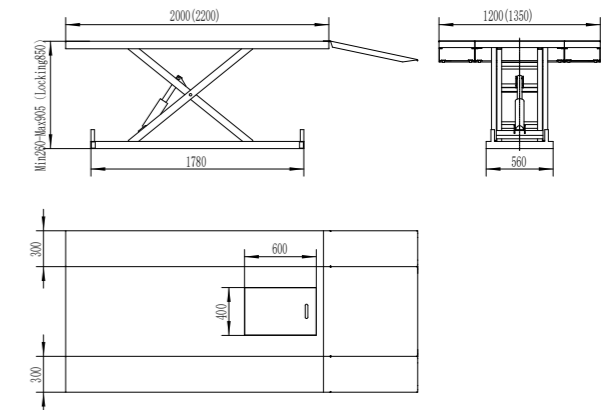

FEATURES 产品特点

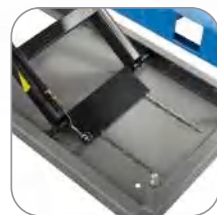

Laser-cutting safety lock
激光切割安全锁



Front-wheel clamp
手动可调节前轮夹具



Rear opening for dismantling wheel
便于后轮拆卸



Safety valves against hose breaking
安全阀确保使用安全

STANDARD 标准配置



CE-norm control box
欧标控制盒



Standard controller for lifting and lowering
标配款控制手柄

OPTIONAL FEATURES 此产品可选升级方案



Optional mobile control unit for lifting and lowering
选配款可移动式控制箱

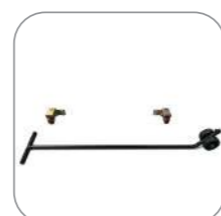

Mobile kit
移动组件

TECHNICAL DATA 技术参数

Model	型号	QYK-ML600	QYK-ML600 + ATV extensions kit
Capacity	举升重量	600kg	600kg
Max. Lifting height	最大举升高度	850mm	850mm
Min. Height	最低高度	260mm	260mm
Platform length	平台长度	2000mm/2200mm	2000mm/2200mm
Overall width	总宽度	600mm/750mm	1200mm/1350mm
Power of motor	电机功率	0.55kW	0.55kW

QYK-ET30



2-Post Parking Lift 双柱停车举升机

- Electric Lock Release
 电动解锁
- Electromagnetic Lowering
 电磁下降

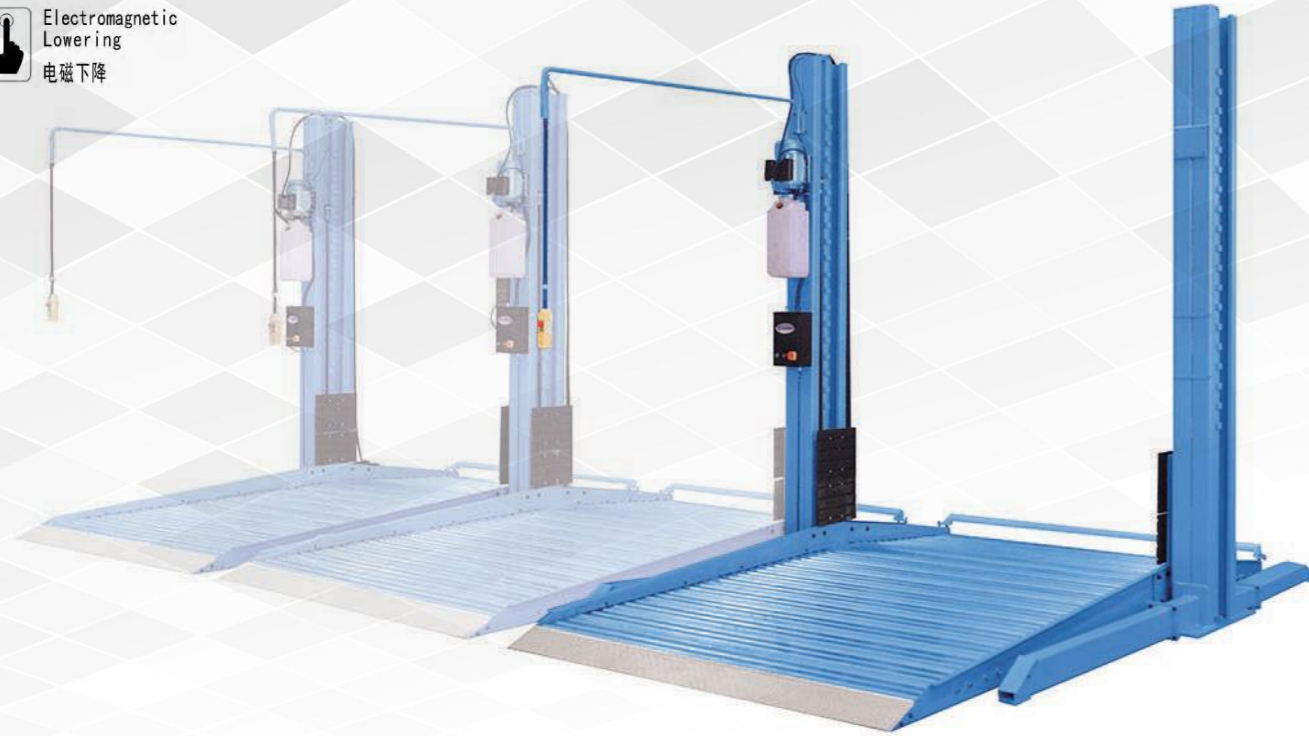

OVERALL DIMENSION 尺寸参数

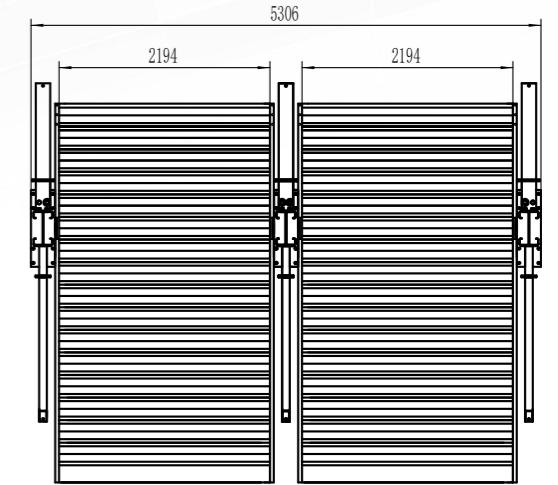
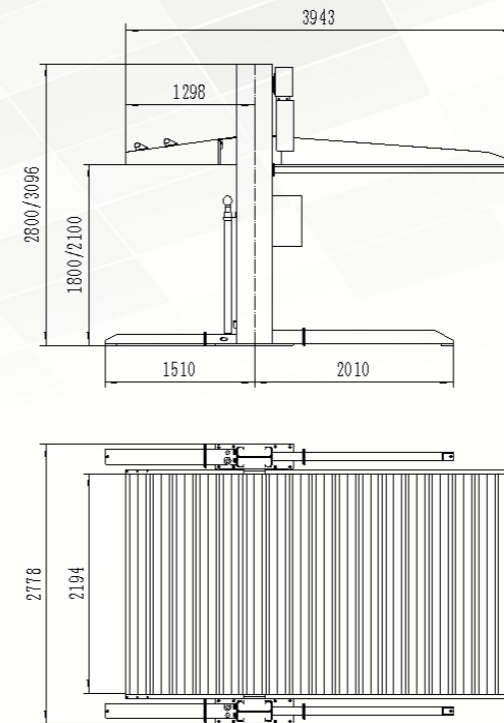

FEATURES 产品特点



Chain protector design
链条防脱防夹手功能



Height limit switch
上限位开关



Safety valves against hose breaking
安全阀确保使用安全



Parking space doubler
上下双层停车设计

STANDARD 标准配置



24v safety control
24v 安全电压操作



Aluminum motor
铝电机散热性能好

TECHNICAL DATA 技术参数

Model	型号	QYK-ET30
Capacity	举升重量	3000kg
Lifting height	举升高度	1800mm/2100mm
Platform length	平台长度	3943mm
Overall height	总高度	2800mm/3096mm
Lifting time	上升时间	45-50s
Power of motor	电机功率	2.2kW